

Accelerating Innovation: Avetec at a Glance

Avetec Completes Aircraft Gearbox Modeling and Simulation with AMESim Greatly Reducing Development Time and Increasing Tradeoff Flexibilities

Designers have a variety of tools to choose from in the modeling and simulation of complex systems. Although fidelity is a top concern, too often designers stay with products they know rather than explore new tools that will match or surpass their fidelity requirements but also greatly reduce the design/test/redesign cycle time and therefore program costs.

Avetec researchers developed a Simulink® model of an advanced aircraft fighter’s gearbox for the Air Force Research Laboratory’s Integrated Vehicle Energy Technology Demonstration (INVENT) program. The figure at the right and the table below-right give indications of the complexity of the system. The model includes time dependent accessory torques and regenerative energy returning to the system via the electrical starter generator as well as gear backlash dynamics.

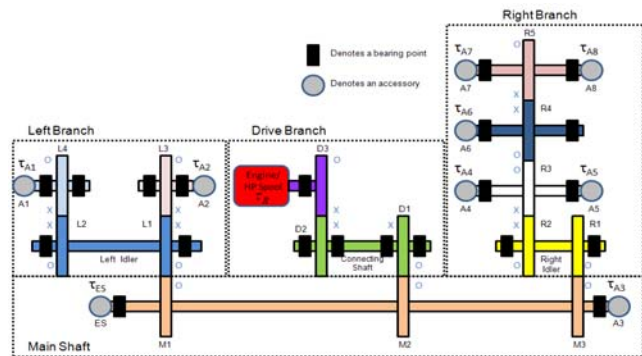

Item	Number
Gears	15
Accessories	9
Shafts	15
Bearing points	21
Source and load torques	11
System parameters	142
Dynamic Equations	88
State Variables ($\theta_i - \theta_j, \omega$)	59

The Simulink® model development and verification took three months. Although the model accurately depicts critical aspects of the gearbox’s dynamics it does not include energy, thermal or other important processes. Furthermore, by the nature of Simulink® and the complexity of the model, it does not lend itself easily to tradeoff studies.

Avetec rebuilt the gearbox model using several other M&S tools. AMESim, by LMS International, proved to be the most powerful and easiest to use. After two days of training, the original gearbox was rebuilt in AMESim and verified in less than two days! In AMESim the schematic becomes the dynamic model as shown in the graphic below. Thus the formulation of the differential equations and associated coding becomes a drag and drop process from extensive multi-domain libraries. The physics is automatically contained in the icons and their connection, thus completing tradeoff studies in hours or days instead of weeks or months. Note how the AMESim working dynamic model resembles the original schematic.

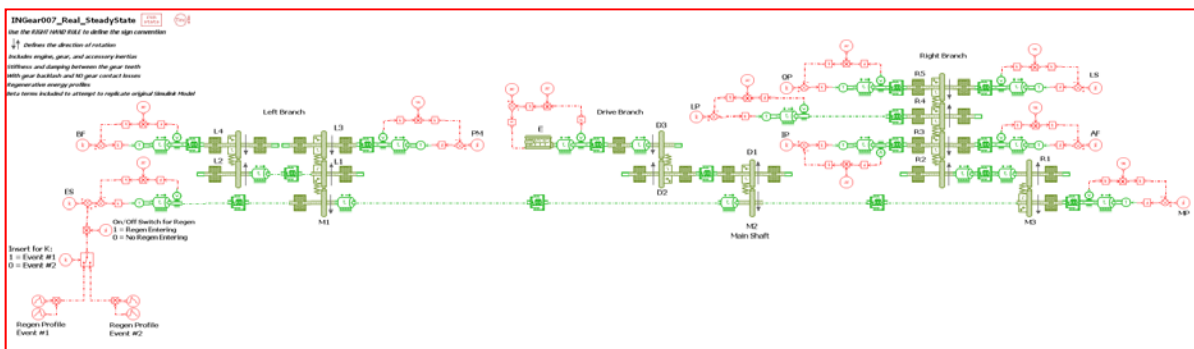

For more information contact Dr. Tony Corvo at (937) 322-5000 x2065 or at tcorvo@avetec.org.